

**NASA-6822VLLA**  
(Embedded Single Board Computer)

**User's Manual**

## **COPYRIGHT<sup>®</sup>**

All rights reserved. The information contained in this guide has been validated and reviewed for accuracy. No patent liability is assumed with respect to the use of the information contained herein. While every precaution has been taken in the preparation of this guide, the Manufacturer assumes no responsibility for errors or omissions.

No part of this publication may be reproduced, stored in a retrieval system, or transmitted in any form or by any means, electronic, mechanical, photocopying, recording, or otherwise, without the prior written permission of Manufacturer.

## **TRADEMARK<sup>™</sup>**

Intel<sup>®</sup>, Pentium<sup>®</sup> and MMX<sup>®</sup> are registered trademarks of Intel<sup>®</sup> Corporation.

Microsoft<sup>®</sup> and Windows<sup>®</sup> are registered trademarks of Microsoft Corporation.

All products and company names are trademarks or registered trademarks of their respective holders.

These specifications are subject to change without notice.

September 2003

# CONTENTS

<b>SECTION 1 INTRODUCTION</b>	4
1.1 Description	4
1.2 Features	4
1.3 Specifications	5
1.4 Pictures of NASA-6822VLLA	6
<b>SECTION 2 INSTALLATIONS</b>	7
2.1 System Installation	8
2.1.1 CPU Installation	9
2.1.2 Heat Sink Installation	10
2.1.3 Memory Module Installation	11
2.1.4 Setting Jumper and DIP Switches	11
2.2 Jumper Setting	11
2.3 Connector' s Description	13
<b>SECTION 3 AWARD BIOS SETUP</b>	22
3.1 BIOS Instructions	24
3.2 Main Menu	24
3.3 Standard CMOS Features	24
3.4 IDE Adapters	24
3.5 Advanced BIOS Features	27
3.6 Advanced Chipset Features	29
3.7 Integrated Peripherals	31
3.8 Power Management Setup	33
3.9 PnP/PCI Configurations	35
3.10 PC Health Status	46
3.11 Frequency/Voltage Control	47
3.12 Load Fail-Safe Default	48
3.13 Load Optimized Defaults	49
3.14 Supervisor/User Password Setting	50
3.15 Exit Selecting	51
<b>SECTION 4 BIOS SETUP FOR PANEL PC BASING ON 6822</b>	39

**SECTION 1**

## INTRODUCTION

### 1.1 Description

The NASA-6822 Series all-in-one single board computer is optimized for socket 370 FC-PGA processor, supporting 100MHz and 133 MHz Front Side Bus, the memory can accommodate is up to 512MB DDR SDRAM. This board is based on the VIA<sup>®</sup> 8623 (CLE266) chipset and is fully designed for harsh industrial environment. The NASA-6822 series is with integrated LCD/VGA, AC97 Audio function and on board dual 10/100 Mbps Ethernet.

The other I/O function include four serial ports, one parallel port, two IDE interface, one FDC interface, four USB2.0 ports, Watch Dog Timer, DOC and PS/2 Keyboard & Mouse.

### 1.2 Features

- ◆ Socket 370 for Intel<sup>®</sup> Celeron™ / Pentium<sup>®</sup> !!! / VIA<sup>®</sup> C3 processor
- ◆ VIA<sup>®</sup> VT8623 + VT8235 AGPset (CLE266)
- ◆ Support 512MB DDR SDRAM (Max.) Memory
- ◆ Front Side Bus Frequency: 100/133 MHz
- ◆ VIA<sup>®</sup> VT8623 chip integrated LVDS/TTL panel interface
- ◆ CRT VGA supported
- ◆ AGP 8x supported
- ◆ 64MB video share memory
- ◆ Hardware MPEG-II engine on chip
- ◆ Dual 10/100 Mbps Ethernet interface using Realtek<sup>®</sup> RTL8100BL chip
- ◆ AC97 Audio
- ◆ 4 x COM ports (2 external, 2 pin header on board)
- ◆ 4 x USB2.0
- ◆ Software programmable watchdog timer
- ◆ S-Video TV-out Function
- ◆ Single DC 19V Power Input
- ◆ PS2 Keyboard and PS/2 Mouse Connector
- ◆ 1 x Printer Port ,
- ◆ 1 x 44pin IDE Connector , 1 x 40pin IDE Connector
- ◆ Hardware Monitoring

### 1.3 Specifications

Model No.	NASA-6822VLLA
Applications	Designed for industrial, medical, and military mission critical applications
Processor	VIA C3 Low power 1GHz or 1.2GHz CPU
Chipset	VIA CLE266 (Northbridge : VT8623, Southbridge: 8235)
FSB	Support 66 / 100 / 133 MHz
System RAM	one socket support up to 1GB high speed DDR RAM
LCD flat panel	Support up to 1600 x 1200 resolutions with LVDS and TTL
VGA	Support second monitor
AGP	Support 4X, 8X AGP speed
Video Memory	Support from 16M, 32M, up to 64M share memory
MPEG-II chip	Support hardware MPEG-I, MPEG-II video and movies
LAN	Dual fast 100/10 Mbps Ethernets support networking
USB 2.0	Support up to 6 x USB 2.0 (4 outside and 2 inside onboard)
Serial port	Support 4 x COM ports (2 outside, 2 inside), 3 x RS232, 1 x RS232 / 422 / 485.
Keyboard	1 x PS2 type keyboard port
Mouse	1 x PS2 type mouse port
Printer port	1 x LPT port for printer interface
PCI ver. 2.2	Support PCI version 2.2
PCI IDE port	Support ATA-100 x 2 up to 4 devices
Audio jack	Support external speaker or microphone function
IrDA	By Pin header
Form factor	190 x 125 mm

### 1.4 Picture of NASA-6822VLLA



**SECTION 2****INSTALLATIONS****2.1 System Installation****2.1.1 CPU**

Only VIA C3 1.0GHz or 1.2GHz CPU can be used on this mainboard.

**Note** : BIOS setting must select 133MHz as CPU clock speed and 7.5 ratio. You can also select a lower ratio than 7.5 in order to reduce the thermal heat of the system.

**2.1.2 CPU Installation**

Carefully follow the steps below in order to install the CPU:

1. Check and confirm that the jumpers are correctly set for the CPU you are going to install (figure 3).
2. Lift the releasing lever of the Socket 370.
3. Align the pins of the CPU against the pinholes of the Socket 370. Be sure to pay attention to the orientation of the CPU.
4. Push down the CPU into the Socket 370.
5. Push down the release lever and lock it against the key hook.

6. Hook the hole in ZIF clip for the CPU cooling fan onto the notch on the socket 370.
7. Place the CPU cooling fan atop the CPU surface.
8. Push down the opposite side of the ZIF clip and hook it.
9. Slide the head of the clip to left and lock it.
10. Connect the cooling fan cable to the socket as shown below. Be careful not to place the cable on the CPU cooling fan.

### **Removing a CPU:**

1. Before removing the CPU, turn off the NASA-6822 Series power; then wait for about 20 minutes until the heat radiation plate of the cooling fan and the CPU cool down.
2. To remove the CPU, lift the releasing lever of the Socket 370.

Note: The CPU and the heat radiation plate are hot. They may cause burns.

**To remove the CPU, reverse the installation steps.**

### **2.1.2 Heat Sink & Retention Module Installation**

It is highly recommended that only NASA-6822 Heat Sink + Fan (Figure 4), designed for use in the chassis be used -- the use of other heat sinks, including those boxed with CPUs, may result in damage to the NASA-6822 SBC.

Make sure that good contact is made between the processors and the heat sinks. Insufficient contact, incorrect types of heat sinks, fans, or thermal compound used or improper amount of thermal compound applied on the CPU die can cause the processors to overheat, which may crash the system.

The Retention Module can prevent the board to crooked, so user must add the Retention Module to hold up the weight of Heat Sink & Fan.

### **2.1.3 Memory Module Installation**

Figure 5 display the notch marks and what they should look like on your DIMM memory module.

DIMMs have 184-pins and two notches, that will match with the onboard DIMM socket. DIMM modules are installed by placing the chip firmly into the socket at a 90-degree angle and pressing straight down (figure 6) until it fits tightly into the DIMM socket.

Carefully follow the steps below in order to install the DIMMs:

1. To avoid generating static electricity and damaging the DIMM, ground yourself by touching a grounded metal surface or using a ground scrap before you touch the DIMM.
2. Do not touch the connector of the DIMM. Dirt residue may cause a malfunction.
3. Hold the DIMM with its notch to the front side of the NASA-6822 Series and insert it completely into the socket. A DIMM should be inserted into the inner socket first. Guiding the hole at each end of the DIMM over the retaining post at each end of the DIMM socket.
4. If you install two DIMMs, install the second DIMM using the same procedure as above.
5. If DIMM does not go in smoothly, do not force it. Pull it all the way out and try again.
6. Make sure the DIMM is properly installed and locked by the tabs on both sides of the socket.

#### **Removing a DIMM:**

To remove the DIMM, use your fingers or a small screwdriver to carefully push away the plastic tabs that secure the DIMM at each end. Lift it out of the socket.

**Make sure you store the DIMM in an anti-static bag and must be populated the same size and manufactory of memory modules. .**

### **2.1.4 Setting Jumpers and DIP Switches**

There are jumpers and DIP-switches on the system board of the NASA-6822 Series. You can set the jumpers to make the necessary operations.

For any three-pin jumpers (figure 7), the jumper setting is 1-2 when the jumper connects pins 1 and 2. The setting is 2-3 when pins 2 and 3 are connected and so on. You see a number " 1 " and a " 3 " printed on the circuit board to identify these

pins. And also, there is a second way of indication – one of the lines surrounding jumpers is thick, which indicates pin NO.1.

To move a jumper from one position to another, use needle-nose pliers or tweezers to pull the pin cap off the pins and move it to the desired position.

### 2.3 Jumper Setting

#### Table for Jumper Location Description:

Use the information in the following table to change the jumpers and the DIP switch.

Jumpers	Functions
JBAT1	Clear CMOS Setting Select
JP1	LCD Panel Voltage Select
J2	Power Bottom
J3	Reset
J6,J7.J8	COM2 RS232/422/485
J11	COM4 Setting Select
J12	COM1 Setting Select
J13	COM3 Setting Select
J14	COM2 Setting Select

#### ◆ Clear CMOS Setting Select: JBAT1

Function	JP1	
Normal (Default)	1-2	
Clear CMOS	2-3	

#### ◆ LCD Panel Voltage Select: JP1

Function	JP1	
5V	1-2	
3.3V	2-3	

#### ◆ COM2 RS232/422/485 Setting Select: JP2

Function	J6		J7		J8	
	1-2	2-3	1-2	2-3	1-2	3-4
RS-232	On	Off	Off	On	Off	Off
RS-422/485	Off	On	On	Off	On	On

• Figure:

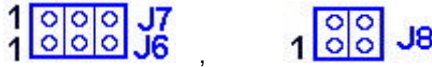

- ◆ **J11 COM4 Setting Select: J11**  
This jumper setting is select pin9 function.

Function	JP11
+5V	1-2
RI (Default)	3-4
+12V	5-6

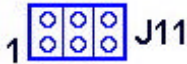

- ◆ **J12 COM1 Setting Select: J12**  
This jumper setting is select pin9 function.

Function	JP11
+5V	1-2
RI (Default)	3-4
+12V	5-6

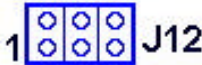

- ◆ **J13 COM3 Setting Select: J13**  
This jumper setting is select pin9 function.

Function	JP11
+5V	1-2
RI (Default)	3-4
+12V	5-6

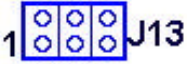

- ◆ **J14 COM2 Setting Select: J14**  
This jumper setting is select pin9 function.

Function	JP11
+5V	1-2
RI (Default)	3-4
+12V	5-6

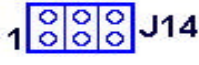

- **Figure:**

## 2.4 Connector's Description

### Table for Connector's Location Description:

Use the information in the following table to change the connector.

Connectors	Functions
IDE1	Primary IDE Connector
IDE2	Secondary IDE Connector

FAN1	Power Fan Connector
TTL	LCD Panel Signal Connector
LVDS	LVDS Panel Signal Connector
JVGA	VGA Signal Pin-Header Connector
JCOM1	COM1 Pin-Header Connector
COM3	COM3 Pin-Header Connector
COM4	COM4 Pin-Header Connector
IR1	IR Pin-Header Connector
J10	Audio Pin-Header Connector
CN9	Parallel Port Connector
Power1	Power Din Connector
KB1	Keyboard/Mouse Connector
S-Video	S-Video TV-out Connector
COM1-2	COM1/2 RS-232 Serial Port Connector
LINO1	Audio Line-out Connector
U12	LAN & USB1/2 Connector
U13	LAN & USB3/4 Connector
VGA1	CRT VGA Port Connector

◆ **Primary IDE Connector (40-pin 2.54mm Pitch Pin-Header with Housing): IDE1**

Pin #	Assignment	Pin #	Assignment
1	Reset IDE	2	Ground
3	Host Data 7	4	Host Data 8
5	Host Data 6	6	Host Data 9
7	Host Data 5	8	Host Data 10
9	Host Data 4	10	Host Data 11
11	Host Data 3	12	Host Data 12
13	Host Data 2	14	Host Data 13
15	Host Data 1	16	Host Data 14
17	Host Data 0	18	Host Data 15
19	Ground	20	No Connect
21	DRQ 0	22	Ground
23	Host IOW	24	Ground
25	Host IOR	26	Ground
27	IOCHRDY	28	Host ALE
29	DACK 0	30	Ground
31	IRQ 14	32	No Connect
33	Address 1	34	No Connect
35	Address 0	36	Address 2
37	Chip Select 0	38	Chip Select 1

39	Activity	40	Ground
----	----------	----	--------

◆ **Secondary IDE Connector (44-pin 2.00mm Pitch Pin-Header with Housing): IDE2**

Pin #	Assignment	Pin #	Assignment
1	Reset IDE	2	Ground
3	Host Data 7	4	Host Data 8
5	Host Data 6	6	Host Data 9
7	Host Data 5	8	Host Data 10
9	Host Data 4	10	Host Data 11
11	Host Data 3	12	Host Data 12
13	Host Data 2	14	Host Data 13
15	Host Data 1	16	Host Data 14
17	Host Data 0	18	Host Data 15
19	Ground	20	No Connect
21	DRQ 1	22	Ground
23	Host IOW	24	Ground
25	Host IOR	26	Ground
27	IOCHRDY	28	Host ALE
29	DACK 1	30	Ground
31	IRQ 15	32	No Connect
33	Address 1	34	No Connect
35	Address 0	36	Address 2
37	Chip Select 0	38	Chip Select 1
39	Activity	40	Ground
41	+5V	42	+5V
43	Ground	44	No Connect

◆ **CPU Fan Connector: FAN1**

Pin #	Assignment	
1	Ground	
2	+12V	
3	Fan Status Signal	

◆ **LCD Panel Signal Pinout: JTTL1(24BIT)**

Pin #	Assignment	Pin #	Assignment
1	B0	2	B1
3	B2	4	B3
5	G4	6	G5
7	R2	8	R3
9	B4	10	B5

11	B6	12	B7
13	G6	14	G7
15	R4	16	R5
17	G0	18	G1
19	G2	20	G3
21	R0	22	R1
23	R6	24	R7
25	ENPVDD	26	Data Clock
27	ENPVEE	28	Data Enable
29	FPBKLP	30	H-Sync
31	GND	32	V-Sync
33	GND	34	Power Good
35	GND	36	PVDD
37	GND	38	PVDD
39	GND	40	PVDD

**18 Bit LCD Panel Pin-out**

BLUE	GREEN	RED
B0 → NC	G0 → NC	R0 → NC
B1 → NC	G1 → NC	R1 → NC
B2 → B0	G2 → G0	R2 → R0
B3 → B1	G3 → G1	R3 → R1
B4 → B2	G4 → G2	R4 → R2
B5 → B3	G5 → G3	R5 → R3
B6 → B4	G6 → G4	R6 → R4
B7 → B5	G7 → G5	R7 → R5



• Figure:

◆ **LVDS Panel Signal Pinout: LVDS**

Pin#	Assignment	Pin#	Assignment
1	PVDD	2	A4-
3	PVDD	4	A4+
5	A0-	6	A5-
7	A0+	8	A5+
9	A1-	10	A6-
11	A1+	12	A6+
13	A2-	14	A7-
15	A2+	16	A7+
17	A3-	18	CLK2-
19	A3+	20	CLK2+
21	CLK1-	22	GND
23	CLK1+	24	GND

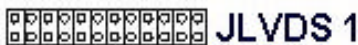

• Figure:

◆ **VGA Connector Pinout: JVGA**

Pin #	Assignment	Pin #	Assignment
1	Red	2	Serial Data
3	Green	4	Serial CLK
5	Blue	6	GND
7	V_SYNC	8	GND
9	H_SYNC	10	GND

JVGA 1



• Figure:

1

◆ **JCOM1 Connector (2.00mm Pin-Header) : JCOM1**

Pin #	Assignment	Pin #	Assignment
1	DCD (Data Carrier Detect)	2	RXD (Receive Data)
3	TXD (Transmit Data)	4	-DTR (Data Terminal Ready)
5	Ground	6	-DSR (Data Set Ready)
7	-RTS (Request to Send)	8	-CTS (Clear to Send)
9	RI (Ring Indicator)	10	No Connect



JCOM1

• Figure:

◆ **COM3 Connector (2.00mm Pin-Header) : COM3**

Pin #	Assignment	Pin #	Assignment
1	DCD (Data Carrier Detect)	2	RXD (Receive Data)
3	TXD (Transmit Data)	4	-DTR (Data Terminal Ready)
5	Ground	6	-DSR (Data Set Ready)
7	-RTS (Request to Send)	8	-CTS (Clear to Send)
9	RI (Ring Indicator)	10	No Connect



COM3

• Figure:

1

◆ **COM4 Connector (2.00mm Pin-Header) : COM4**

Pin #	Assignment	Pin #	Assignment
1	DCD (Data Carrier Detect)	2	RXD (Receive Data)
3	TXD (Transmit Data)	4	-DTR (Data Terminal Ready)
5	Ground	6	-DSR (Data Set Ready)
7	-RTS (Request to Send)	8	-CTS (Clear to Send)
9	RI (Ring Indicator)	10	No Connect



• Figure:

◆ IR Connector (2.00mm Pin-Header) : IR1

Pin#	Assignment
1	Vcc+5V
2	No Connect
3	IRTx
4	GND
5	IRTx



• Figure:

◆ Audio Connector (2.00mm Pin-Header) : J10

Pin #	Assignment	Pin #	Assignment
1	RIGHT	2	LEFT
3	GND	4	MIC1
5	NC		



• Figure:

◆ Parallel Port Connector :CN9

Pin #	Assignment	Pin #	Assignment
1	Line Printer Strobe	2	PD 0, Parallel Data 0
3	PD 1, Parallel Data 1	4	PD 2, Parallel Data 2
5	PD 3, Parallel Data 3	6	PD 4, Parallel Data 4
7	PD 5, Parallel Data 5	8	PD 6, Parallel Data 6
9	PD 7, Parallel Data 7	10	ACK, Acknowledge
11	Busy	12	Paper Empty
13	Select	14	Auto Feed
15	Error	16	Initialize
17	Select	18	Ground
19	Ground	20	Ground
21	Ground	22	Ground
23	Ground	24	Ground
25	Ground	26	N/A

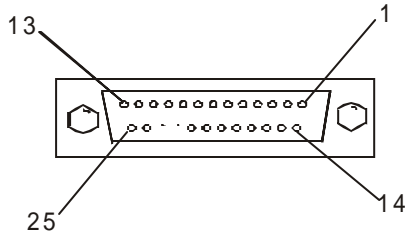

• Figure:

◆ DC+19V Power DIN Connector :Power1

Pin #	Assignment	Pin #	Assignment
1	+19V	4	+19V
3	Ground	4	Ground



• Figure:

◆ PS/2 Keyboard Connector (Mini Din 6 Pin):KB1

Pin #	Assignment	Pin #	Assignment
1	Keyboard Data	2	NC
3	Ground	4	+5V
5	Keyboard Clock	6	NC

◆ PS/2 Mouse Connector (Mini Din 6 Pin):

Pin #	Assignment	Pin #	Assignment
1	NC	2	Mouse Data
3	Ground	4	+5V
5	NC	6	Mouse Clock

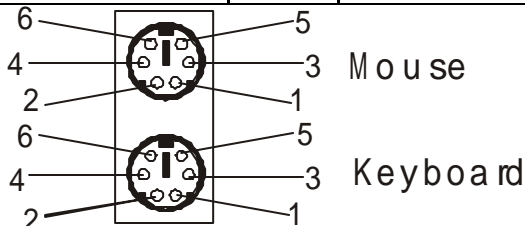

• Figure:

◆ S-Video Connector (Mini Din 4 Pin):S-Video

Pin #	Assignment	Pin #	Assignment
1	Ground	2	Ground

3	LUM	4	CHROM
---	-----	---	-------

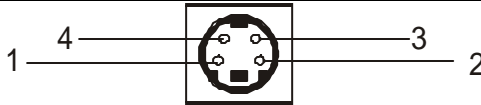

• Figure:

◆ **COM1 RS-232 Serial Port Connector (D-SUB 9-pin Male): COM1-2**

Pin #	Assignment	Pin #	Assignment
1	DCD (Data Carrier Detect)	2	RXD (Receive Data)
3	TXD (Transmit Data)	4	DTR (Data Terminal Ready)
5	Ground	6	DSR (Data Set Ready)
7	RTS (Request to Send)	8	CTS (Clear to Send)
9	RI (Ring Indicator)		

◆ **COM2 RS-232 Serial Port Connector (D-SUB 9-pin Male): COM1-2**

Pin #	Assignment	Pin #	Assignment
1	DCD (Data Carrier Detect)	2	RXD (Receive Data)
3	TXD (Transmit Data)	4	DTR (Data Terminal Ready)
5	Ground	6	DSR (Data Set Ready)
7	RTS (Request to Send)	8	CTS (Clear to Send)
9	RI (Ring Indicator)		

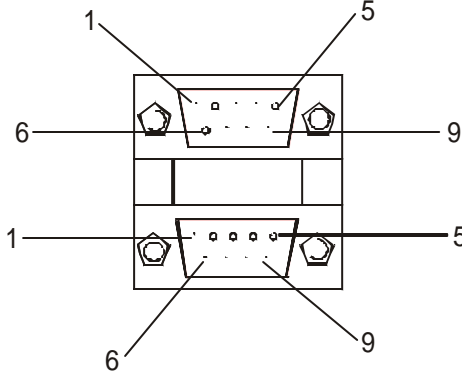

• Figure:

◆ **Audio Connector (3.5mm Phone Jack): LINO1**

Pin #	Assignment	Pin #	Assignment
1	Lineout-R	2	Ground
3	Ground	4	Lineout-L



• Figure:

◆ LAN1 & USB1/2 Connector : U12

Pin #	Assignment	Pin #	Assignment
<b>LAN</b>			
1	Transmit Data (+)	5	NC
2	Transmit Data (-)	6	Receive Data (-)
3	Receive Data (+)	7	NC
4	NC	8	NC
<b>USB</b>			
1	VCC	2	USB Data-
3	USB Data+	4	Ground



• Figure:

◆ LAN1 & USB3/4 Connector : U13

Pin #	Assignment	Pin #	Assignment
<b>LAN</b>			
1	Transmit Data (+)	5	NC
2	Transmit Data (-)	6	Receive Data (-)
3	Receive Data (+)	7	NC
4	NC	8	NC
<b>USB</b>			
1	VCC	2	USB Data-
3	USB Data+	4	Ground



• Figure:

◆ CRT VGA Port Connector (D-SUB 15-pin Female): VGA1

Pin #	Assignment	Pin #	Assignment
1	Red Color Signal	2	Green Color Signal
3	Blue Color Signal	4	NC
5	Ground	6	Ground
7	Ground	8	Ground
9	NC	10	Ground
11	NC	12	VGA DDA
13	H-Sync.	14	V-Sync.

15	SPCLK	
----	-------	--

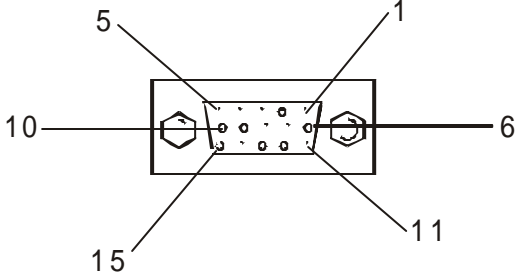

• Figure:

## SECTION 3

### AWARD BIOS SETUP

#### 3.1 BIOS Instructions

Award' s ROM BIOS provides a built-in Setup program, which allows user to modify the basic system configuration and hardware parameters. The modified data will be stored in a battery-backed CMOS, so that data will be retained even when the power is turned off. In general, the information saved in the CMOS RAM will stay unchanged unless there is a configuration change in the system, such as hard drive replacement or a device is added.

It is possible for the CMOS battery to fail, this will cause data loss in the CMOS only. If this does happen you will need to reconfigure your BIOS settings.

#### 3.2 Main Menu

Once you enter the AwardBIOS™ CMOS Setup Utility, the Main Menu will appear on the screen. The Main Menu allows you to select from several setup functions and

two exit choices. Use the arrow keys to select among the items and press <Enter> to accept and enter the sub-menu.

### Phoenix – Award BIOS CMOS Setup Utility

<ul style="list-style-type: none"> <li>◆ Standard CMOS Feature</li> <li>◆ Advanced BIOS Feature</li> <li>◆ Advanced Chipset Feature</li> <li>◆ Integrated Peripherals</li> <li>◆ Power Management Setup</li> <li>◆ PnP/PCI Configurations</li> <li>◆ PC Health Status</li> </ul>	<ul style="list-style-type: none"> <li>◆ Frequency/Voltage Control</li> <li>◆ Load Fail-Safe Defaults</li> <li>◆ Load Optimized Defaults</li> <li>◆ Set Supervisor Password</li> <li>◆ Set User Password</li> <li>◆ Save &amp; Exit Setup</li> <li>◆ Exit Without Saving</li> </ul>
Esc: Quit	↑↓←→: Select Item
F10: Save & Exit Setup	
Time, Date, Hard Disk Type....	

Note: that a brief description of each highlighted selection appears at the bottom of the screen.

#### Setup Items:

The main menu includes the following main setup categories. Recall that some systems may not include all entries.

#### Standard CMOS Features:

Use this menu for basic system configuration. See Section 2 for the details.

#### Advanced BIOS Features:

Use this menu to set the Advanced Features available on your system. See Section 3 for the details.

#### Advanced Chipset Features:

Use this menu to change the values in the chipset registers and optimize your system's performance. See section 4 for the details.

#### Integrated Peripherals:

Use this menu to specify your settings for integrated peripherals. See section 4 for the details.

#### Power Management Setup:

Use this menu to specify your settings for power management. See section 5 for the details.

**PnP / PCI Configuration:**

This entry appears if your system supports PnP / PCI. See section 6 for the details.

**PC Health Status:**

Use this menu to show your system temperature, speed and voltage status.

**Frequency/Voltage Control:**

Use this menu to specify your settings for frequency/voltage control. See section 7 for the details.

**Load Fail-Safe Defaults:**

Use this menu to load the BIOS default values for the minimal/stable performance for your system to operate. See section 8 for the details.

**Load Optimized Defaults:**

Use this menu to load the BIOS default values that are factory settings for optimal performance system operations. While Award has designed the custom BIOS to maximize performance, the factory has the right to change these defaults to meet their needs. See section 8 for the details.

**Supervisor/User Password:**

Use this menu to set User and Supervisor Passwords. See section 9 for the details.

**Save & Exit Setup:**

Save CMOS value changes to CMOS and exit setup. See section 10 for the details.

**Exit Without Save:**

Abandon all CMOS value changes and exit setup. See section 10 for the details.

### 3.3 Standard CMOS Features

The items in Standard CMOS Setup Menu are divided into 10 categories. Each category includes no, one or more than one setup items. Use the arrow keys to highlight the item and then use the <PgUp> or <PgDn> keys to select the value you want in each item.

#### Standard CMOS Features

<p><b>Date (mm:dd:yy):</b> [ Mon, Aug 6 2003 ]  <b>Time (hh:mm:ss):</b> [ 16:19:20 ]</p> <p>➤ <b>IDE Primary Master</b> [ 2557 MB ]          ➤ <b>IDE Primary Slave</b> [ None ]          ➤ <b>IDE Secondary Master</b> [ None ]          ➤ <b>IDE Secondary Slave</b> [ None ]</p> <p><b>Video</b> [ EGA/VGA ]  <b>Halt On</b> [ All, But Keyboard ]</p> <p><b>Based Memory</b> [ 640K ]  <b>Extended Memory</b> [ 64512K ]  <b>Total Memory</b> [ 65536K ]</p>	<p><b>Item Help</b></p> <hr/> <p><b>Menu Level</b> ➤</p> <p><b>Change day, month, year</b></p>
<p>↑↓←→Move Enter: Select +/-/PU/PD: Value F10: Save ESC: Exit F1: General Help          F5: Previous Values F6: Fail-safe defaults F7: Optimized Defaults</p>	

**Date:** Options Month/DD/YYYY

Set the system date. Note that the ‘ Day’ automatically changes when you set the date.

**Time:** Options HH : MM : SS

Set the system time.

**IDE Primary Master:** Options are in its sub menu (described in Table 3)

Press <Enter> to enter the sub menu of detailed options.

**IDE Primary Slave:** Options are in its sub menu (described in Table 3)

Press <Enter> to enter the sub menu of detailed options.

**IDE Secondary Master:** Options are in its sub menu (described in Table 3)

Press <Enter> to enter the sub menu of detailed options.

**IDE Secondary Slave:** Options are in its sub menu (described in Table 3)

Press <Enter> to enter the sub menu of detailed options.

**Video:** Options EGA/VGA/CGA 40/CGA 80/MONO

Select the default video device.

**Halt On:** Options All Errors/No Errors/All, but Keyboard/All, but Diskette/All, but Disk/Key

Select the situation in which you want the BIOS to stop the POST process and notify you.

**Base Memory:** Option N/A

Displays the amount of conventional memory detected during boot up.

**Extended Memory:** Option N/A

Displays the amount of extended memory detected during boot up

**Total Memory:** Option N/A

Displays the total memory available in the system

**3.4 IDE Adapters**

The IDE adapters control the hard disk drive. Use a separate sub menu to configure each hard disk drive.

**Phoenix – Award BIOS CMOS Setup Utility**  
**IDE Primary Master**

<b>IDE HDD Auto-Detection</b>	<b>[ Press Enter ]</b>	<b>Item Help</b>
<b>IDE Primary Master Access Mode</b>	<b>[ Auto 2557 MB ]</b> <b>[ Auto ]</b>	<b>Menu Level</b> >>
<b>Cylinder</b>	<b>[ 4956 ]</b>	<b>To auto-detect the HDD's size, head... on this channel</b>
<b>Head</b>	<b>[ 16 ]</b>	
<b>Precomp</b>	<b>[ 0 ]</b>	
<b>Landing Zone</b>	<b>[ 4955 ]</b>	
<b>Sector</b>	<b>[ 63 ]</b>	
↑↓←→Move Enter: Select +/-/PU/PD: Value F10: Save ESC: Exit F1: General Help F5: Previous Values F6: Fail-safe defaults F7: Optimized Defaults		

**IDE HDD Auto-detection:** Options Press Enter

Press Enter to auto-detect the HDD on this channel. If detection is successful, it fills the remaining fields on this menu.

**IDE Primary Master:** Options None, Auto and Manual

Selecting "Manual" lets you set the remaining fields on this screen. Selects the type of fixed disk. "User Type" will let you select the number of cylinders, heads, etc. Note: PRECOMP=65535 means NONE !

**Capacity:** Options Auto Display your disk drive size

Disk drive capacity (Approximated). Note that this size is usually slightly greater than the size of a formatted disk given by a disk-checking program.

**Access Mode:** Options Normal, LBA, Large and Auto

Choose the access mode for this hard disk

The following options are selectable only if the ' IDE Primary Master' item is set to ' Manual'

**Cylinder:** Options Min = 0, Max = 65535

Set the number of cylinders for this hard disk.

**Head:** Options Min = 0, Max = 255

Set the number of read/write heads

**Precomp:** Options Min = 0, Max = 65535

\*\*\*\* **Warning:** Setting a value of 65535 means no hard disk

**Landing zone:** Options Min = 0, Max = 65535

\*\*\*\*

**Sector:** Options Min = 0, Max = 255

Number of sectors per track

### 3.5 Advanced BIOS Features

This section allows you to configure your system for basic operation. You have the opportunity to select the system's default speed, boot-up sequence, keyboard operation, shadowing and security.

#### **Phoenix – Award BIOS CMOS Setup Utility Advanced BIOS Features**

<p><b>CPU Internal Cache</b> [ Enabled ]  <b>External Cache</b> [ Enabled ]  <b>CPU L2 Cache ECC Checking</b> [ Enabled ]  <b>Quick Power On Self Test</b> [ Enabled ]  <b>First Boot Device</b> [ HDD-0 ]  <b>Second Boot Device</b> [ CDROM ]  <b>Third Boot Device</b> [ HDD-1 ]  <b>Boot Other Device</b> [ Enabled ]  <b>Boot Up NumLock Status</b> [ On ]  <b>Gate A20 Option</b> [ Fast ]  <b>Typematic Rate Setting</b> [ Enabled ]  <b>Typematic Rate (Chars/Sec)</b> [ 30 ]  <b>Typematic Delay (Msec)</b> [ 250 ]  <b>Security Option</b> [ Setup ]  <b>OS Select For DRAM &gt; 64MB</b> [ Non-OS2 ]  <b>Video BIOS Shadow</b> [ Enabled ]  <b>Small Logo (EPA) Show</b> [ Disabled ]</p>	<p style="text-align: center;"><b>Item Help</b></p> <hr/> <p>Menu Level &gt;</p>
<p>↑↓←→Move Enter: Select +/-PU/PD: Value F10: Save ESC: Exit F1: General Help  F5: Previous Values F6: Fail-safe defaults F7: Optimized Defaults</p>	

**CPU Internal Cache/External Cache:**

These two categories speed up memory access. However, it depends on CPU/chipset design.

- Enabled---Enable cache
- Disabled---Disable cache

**CPU L2 Cache ECC Checking:**

This item allows you to enable/disable CPU L2 Cache ECC checking.

The choice: Enabled, Disabled.

**Quick Power On Self Test:**

This category speeds up Power On Self Test (POST) after you power up the computer. If it is set to Enable, BIOS will shorten or skip some check items during POST.

- Enabled---Enable quick POST
- Disabled--- Normal POST

**First/Second/Third/Other Boot Device:**

The BIOS attempts to load the operating system from the devices in the sequence selected in these items.

The Choice: Floppy, LS/ZIP, HDD, SCSI, CDROM and Disabled.

**Boot Up NumLock Status:**

Select power on state for NumLock.

The choice: On, Off

**Gate A20 Option:**

Select if chipset or keyboard controller should control GateA20.

Normal---A pin in the keyboard controller controls GateA20

Fast---Lets chipset control GateA20

**Typematic Rate Setting:**

Keystrokes repeat at a rate determined by the keyboard controller. When enabled, the typematic rate and typematic delay can be selected.

The choice: Enabled, Disabled.

**Typematic Rate (Chars/Sec):**

Sets the number of times a second to repeat a keystroke when you hold the key down.

The choice: 6, 8, 10, 12, 15, 20, 24 and 30.

**Typematic Delay (Msec):**

Sets the delay time after the key is held down before it begins to repeat the keystroke.

The choice: 250, 500, 750 and 1000.

**Security Option:**

Select whether the password is required every time the system boots or only when you enter setup.

System---The system will not boot and access to Setup will be denied if the correct password is not entered at the prompt.

Setup---The system will boot, but access to Setup will be denied if the correct password is not entered at the prompt.

Note: To disable security, select PASSWORD SETTING at Main Menu and then you will be asked to enter password. Do not type anything and just press <Enter>, it will disable security. Once the security is disabled, the system will boot and you can enter Setup freely.

**OS Select For DRAM > 64MB:**

Select the operating system that is running with greater than 64MB of RAM on the system.

The choice: Non-OS2, OS2.

**Video BIOS Shadow:**

Set Video BIOS Shadow to memory.  
The choice: Enabled, Disabled.

**Small Logo (EPA) Show:**

Set the Logo (EPA) show or not.  
The choice: Enabled, Disabled.

**3.6 Advanced Chipset Features**

This section allows you to configure the system based on the specific features of the installed chipset. This chipset manages bus speeds and access to system memory resources, such as DRAM and the external cache. It also coordinates communications between the conventional ISA bus and the PCI bus. It must be stated that these items should never need to be altered. The default settings have been chosen because they provide the best operating conditions for your system. The only time you might consider making any changes would be if you discovered that data was being lost while using your system.

**Phoenix – Award BIOS CMOS Setup Utility  
Advanced Chipset Features**

		Item Help
<b>DRAM Clock/Drive Control</b>	[ Press Enter ]	
<b>AGP &amp; P2P Bridge Control</b>	[ Press Enter ]	
<b>CPU &amp; PCI Bus Control</b>	[ Press Enter ]	<b>Menu Level</b> >
<b>Memory Hole</b>	[ Disabled ]	
<b>VGA Share Memory Size</b>	[ 64M ]	
<b>Select Display Device</b>	[ CRT+LCD ]	
<b>TV_type</b>	[ NTSC ]	
<b>Panel Type</b>	[ 0A ]	
↑↓←→Move Enter: Select +/-/PU/PD: Value F10: Save ESC: Exit F1: General Help F5: Previous Values F6: Fail-safe defaults F7: Optimized Defaults		

**Memory Hole:**

You can reserve this area of system memory for ISA adapter ROM. When this area is reserved, it cannot be cached. The user information of peripherals that need to use this area of system memory usually discusses their memory requirements.  
The choice: Enabled, Disabled.

**VGA Share Memory Size:**

Select VGA memory size.  
The choice: 16M, 32M, 64M. Default is 32M or 64M.

**Select Display Device:**

There are five options for you to choose from :

- CRT+LCD (default is this one) , TV, CRT+TV , CRT, LCD

-

### TV Type :

There are five items for you to choose from : NTSC, PAL, PALM, PALN, PALNc.

The default value of TV system is NTSC for countries in USA, Taiwan, and Japan.

If you are in Europe or other countries than USA / Taiwan / Japan, you have to check which TV system your country is using. Then select the appropriate one.

### Panel Type :

Please review the following BIOS setup table for all NAGASAKI Panel PC design basing on mainboard NASA-6822VLLA.

### BIOS Setting for Nagasaki Panel PCs

Model No.	Size	Resolution	Mainboard	Main → Advanced Chipset → Select Display Device	
				Display Device	Panel Type
PPC-712	7"	640 x 480	NASA-6822	No matter	CRT
PPC-812	8"	640x480	NASA-6822	CRT+LCD	00
PPC-872	8"	640 x 480	NASA-6822	CRT+LCD	00
PPC-1072 -VGA	10.4"	640 x480	NASA-6822	CRT+LCD	00
PPC-1072 -SVGA	10.4"	800 x 600	NASA-6822	CRT+LCD	01
PPC-1272	12.1"	800 x 600	NASA-6822	CRT+LCD	01
PPC-1273	12.1"	800 x 600	NASA-6822	CRT+LCD	01
PPC-1511	15"	1024 x 768	NASA-6822	CRT+LCD	0A
PPC-1513	15"	1024 x 768	NASA-6822	CRT+LCD	0A
PPC-1514	15"	1024 x 768	NASA-P411	CRT+LCD	8
PPC-1572	15"	1024 x 768	NASA-6822	CRT+LCD	0A
PPC-1573	15"	1024 x 768	NASA-6822	CRT+LCD	0A
PPC-1574	15"	1024 x 768	NASA-P411	CRT+LCD	8
PPC-1575	15"	1024 x 768	NASA-6822	CRT+LCD	0A
PPC-1576	15"	1024 x 768	NASA-P411	CRT+LCD	0A
PPC-1577	15"	1024 x 768	NASA-6822	CRT+LCD	0A
PPC-1772	17"	1280 x 1024	NASA-6822	CRT+LCD	0D
PPC-1773	17"	1280 x 1024	NASA-6822	CRT+LCD	0D
PPC-1774	17"	1280 x 769	NASA-6822	CRT+LCD	0C
PPC-1912	19"	1280 x 1024	NASA-6822	CRT+LCD	0D
PPC-2172	21"		NASA-6822	CRT	

### 3.7 Integrated Peripherals

#### Phoenix – Award BIOS CMOS Setup Utility Integrated Peripherals

		Item Help
VIA OnChip IDE Device	[ Press Enter ]	
VIA OnChip PCI Device	[ Press Enter ]	Menu Level >
Super IO Device	[ Press Enter ]	
Init Display First	[ PCI slot ]	
Watch Dog Timer Select	[ Disabled ]	
Onboard Serial Port 3	[ 3E8 ]	
Serial Port 3 Use IRQ	[ IRQ 10 ]	
Onboard Serial Port 4	[ 2E8 ]	
Serial Port 4 Use IRQ	[ IRQ 11 ]	
↑↓←→Move Enter: Select +/-PU/PD: Value F10: Save ESC: Exit F1: General Help F5: Previous Values F6: Fail-safe defaults F7: Optimized Defaults		

#### OnChip IDE/PCI Device:

The integrated peripheral controller contains an IDE interface with support for two IDE channels. Select “Enabled” to activate each channel separately.

The choice: Press Enter.

#### OnChip Primary/Secondary PCI IDE:

The integrated peripheral controller contains an IDE interface with support for two IDE channels. Select “Enabled” to activate each channel separately.

The choice: Enabled, Disabled.

#### IDE Primary/Secondary Master/Slave PIO:

The four IDE PIO (Programmed Input/Output) fields let you set a PIO mode (0-4) for each of the four IDE devices that the onboard IDE interface supports. Modes 0 through 4 provide successively increased performance. In Auto mode, the system automatically determines the best mode for each device.

The choice: Auto, Mode 0, Mode 1, Mode 2, Mode 3 and Mode 4.

#### IDE Primary/Secondary Master/Slave UDMA:

Ultra DMA/33 implementation is possible only if your IDE hard drive supports it and the operating environment includes a DMA driver (Windows 95 OSR2 or a third-party IDE bus master driver). If your hard drive and your system software both support Ultra DMA/33, select “Auto” to enable BIOS support.

The choice: Auto, Disabled.

#### USB Controller:

Select “Enabled” if your system contains a Universal Serial Bus (USB) controller and you have USB peripherals.

The choice: Enabled, Disabled.

**USB Keyboard Support:**

Select “Enabled” if your system contains a Universal Serial Bus (USB) controller and you have a USB keyboard.

The choice: Enabled, Disabled.

**Init Display First:**

This item allows you to decide to active whether PCI Slot or on-chip VGA first.

The choice: PCI Slot, Onboard.

**IDE HDD Block Mode:**

Block mode is also called block transfer, multiple commands, or multiple sector read/write. If your IDE hard drive supports block mode (most new drives do), select Enabled for automatic detection of the optimal number of block read/writes per sector the drive can support.

The choice: Enabled, Disabled

**KBC Input Clock Mode:**

This item allows you to adjust the keyboard input clock.

The choice: 8MHz, 12MHz.

**PWRON After PWR-Fail:**

This item allows you to select if you want to power on the system after power failure.

The choice: Off, On and Former-Sts.

**3.8 Power Management Setup**

The Power Management Setup allows you to configure you system to most effectively save energy while operating in a manner consistent with your own style of computer use.

**Phoenix – Award BIOS CMOS Setup Utility**  
**Power Management Setup**

<p><b>ACPI Function</b> [Enabled]  <b>Power Management Option</b> [User Define]  <b>HDD Power Down</b> [Disabled]  <b>Suspend Mode</b> [Disabled]  <b>Video Off Option</b> [Suspend -&gt; Off]  <b>Video Off Method</b> [V/H Sync+Blank]  <b>MODEM Use IRQ</b> [3]  <b>Soft-Off by PWR-BTN</b> [Instant-Off]  <b>Run VGA BIOS if S3 Resume</b> [Auto]  <b>AC Loss Auto Restart</b> [On]  <b>IRQ/Event Activity Detect</b> [Press Enter]</p>	<p><b>Item Help</b></p> <hr/> <p><b>Menu Level</b> ➤</p>
<p>↑↓←→Move Enter: Select +/-PU/PD: Value F10: Save ESC: Exit F1: General Help  F5: Previous Values F6: Fail-safe defaults F7: Optimized Defaults</p>	

**ACPI Function:**

This item allows you to enable/disable the Advanced Configuration and Power Management (ACPI).

The choice: Enabled, Disabled.

**Power Management:**

This category allows you to select Minimum saving or Maximum Saving.

**HDD Power Down :**

You can choose from Disabled, 1, 2, 3, 4, 5, ... up to 15 minutes.

**Suspend Mode :**

You can choose from Disabled, 1, 2, 4, 6, 8, 10, 20, 30, 40, 60 minutes.

**Video Off Option**

You can choose a) Always on or b) Suspend→ Off

**Video Off Method:**

This determines the manner in which the monitor is blanked. You can choose :

- a) Blank screen : This option only writes blanks to the video buffer.
- b) V/H Sync + Blank :

This selection will cause the system to turn off the vertical and horizontal synchronization ports and write blanks to the video buffer.

- c) DMPS support :

Initial display power management signaling.

**MODEM Use IRQ:**

This determines the IRQ in which the MODEM can use.

The choice: 3, 4, 5, 7, 9, 10, 11 and NA. Default value is 3.

**Soft-Off by PWR-BTN:**

You can choose a) Instant Off or b) Delay 4 seconds. The default value is : Instant off.

Pressing the power button for more than 4 seconds forces the system to enter the Soft-Off state when the system has “hung.”

**Run VGA BIOS if S3 Resume**

**AC Loss Auto Restart**

You can choose from Auto, On, or Off.

When you choose “On”, the system will be automatically powered on when the power plug was plugging into a power socket. If you do not want the system automatically powered off, please select “Off”. Note : the “Auto Power On” is usually used in an automation factory production line. When there is a power off, the computer was turned off. When the power is back, the computer was turned on automatically.

**IRQ / Event Activity Detect**

**3.9 PnP/PCI Configurations**

This section describes configuring the PCI bus system. PCI, or **P**ersonal **C**omputer **I**nterconnect, is a system, which allows I/O devices to operate at speeds nearing the speed the CPU itself uses when communicating with its own special components. This section covers some very technical items and it is strongly recommended that only experienced users should make any changes to the default settings.

**Phoenix – Award BIOS CMOS Setup Utility  
PnP / PCI Configurations**

		Item Help
<b>PNP OS Installed</b>	[No]	
<b>Reset Configuration Data</b>	[Disabled]	Menu Level ➤
<b>Resources Controlled By</b> X IRQ Resources	[Auto (ESCD)] [Press Enter]	Select yes if you are using a plug and play Capable operating system. Select no if you need the BIOS to configure non-boot devices
<b>PCI/VGA Palette Snoop</b>	[Disabled]	
<b>Assign IRQ for VGA</b>	[Enabled]	
<b>Assign IRQ for USB</b>	[Enabled]	
↑↓←→Move Enter: Select +/-PU/PD: Value F10: Save ESC: Exit F1: General Help F5: Previous Values F6: Fail-safe defaults F7: Optimized Defaults		

**PNP OS Installed:**

This item allows you to determine install PnP OS or not.

The choice: Yes, No.

**Reset Configuration Data:**

Normally, you leave this field Disabled. Select “Enabled” to reset Extended System Configuration Data (ESCD) when you exit Setup if you have installed a new add-on and the system reconfiguration has caused such a serious conflict that the operating system cannot boot.

The choice: Enabled, Disabled.

**Resource controlled by:**

The Award Plug and Play BIOS has the capacity to automatically configure all of the boot and Plug and Play compatible devices. However, this capability means absolutely nothing unless you are using a Plug and Play operating system such as Windows<sup>®</sup>95. If you set this field to “Manual” choose specific resources by going into each of the sub menu that follows this field (a sub menu is preceded by a “>”).

The choice: Auto (ESCD), Manual.

**IRQ Resources:**

When resources are controlled manually, assign each system interrupt a type, depending on the type of device using the interrupt.

**PCI / VGA Palette Snoop:**

Leave this field at “Disabled”.

The choice: Enabled, Disabled.

**Assign IRQ for VGA** : select Enabled or Disabled.

**Assign IRQ for USB** : select Enabled or Disabled.

**3.10 PC Health Status**

**Phoenix – Award BIOS CMOS Setup Utility**  
**PC Health Status**

<b>CPU Warning Temperature</b> [ Disabled ] <b>Current CPU Fan Speed</b> [ 5213RPM ] Vtt (V) [ 1.48V ] Vcore (V) [ 1.72V ] 3.3V (V) [ 3.28V ] + 5 V [ 4.97V ] +12 V [ 12.03V ] -12 V [ -12.36V ] -5V [ -4.99V ] VBAT (V) [ 3.07V ] 5VSB (V) [ 4.63V ]	<b>Item Help</b> <hr/> <b>Menu Level</b> ➤
↑↓←→Move Enter: Select +/-PU/PD: Value F10: Save ESC: Exit F1: General Help F5: Previous Values F6: Fail-safe defaults F7: Optimized Defaults	

**CPU Warning Temperature:**

This item will prevent CPU from overheating. The choice: Enabled, Disabled.

**Current CPUFAN Speed:**

Show you the current CPU fan operating speed.

**IN0/1/2 (V):**

Show you the voltage of Vin (0)/(1)/(2).

**+5V/+12V/-12V/-5V:**

Show you the voltage of +5V/+12V/-12V/-5V.

**3.11 Frequency/Voltage Control**

**Phoenix – Award BIOS CMOS Setup Utility  
Frequency /Voltage Control**

<b>VIA C3 Clock Ratio</b> [ Default ] <b>Auto Detect DIMM/PCI CLK</b> [ Disabled ] <b>Spread Spectrum Modulated</b> [ Disabled ] <b>CPU Clock</b> [ 133 ]	<b>Item Help</b> <hr/> <b>Menu Level</b> ➤
↑↓←→Move Enter: Select +/-PU/PD: Value F10: Save ESC: Exit F1: General Help F5: Previous Values F6: Fail-safe defaults F7: Optimized Defaults	

**VIA C3 CPU Clock Ratio :**

The default CPU is 1GHz, the front side bus (FSB) is 133MHz at 7.5 timefolds.

Please choose only “default” or X 7.5 clock ratio. If you choose clock ratio higher than 7.5, the system will not be able to boot up. In this case, you need to erase the CMOS memory in order to let the BIOS setup return to the original default setting values.

#### **Auto Detect DIMM/PCI CLK:**

When “Enabled” , this item will auto detect if the DIMM and PCI socket have devices and will send clock signal to DIMM and PCI devices. When disabled, it will send the clock signal to all DIMM and PCI socket. The choice: Enabled, Disabled.

#### **Spread Spectrum Modulated:**

This item allows you to enable/disable the spread spectrum modulated.

The choice: Enabled, Disabled.

**CPU Clock : there are 133 and 166 in this option.** Please choose only 133 because the CPU built in is a 133 MHz speed at 7.5 clock ratio.

### **3.12 Load Fail-Safe Defaults**

When you press <Enter> on this item you get a confirmation dialog box with a message similar to:

Load Fail-Safe Defaults (Y/N)? **N**

Pressing “Y” loads the BIOS default values for the most stable, minimal-performance system operations.

### **3.13 Load Optimized Defaults**

When you press <Enter> on this item you get a confirmation dialog box with a message similar to:

Load Optimized Defaults (Y/N)? **N**

Pressing “Y” loads the default values that are factory settings for optimal performance system operations.

### **3.14 Supervisor/User Password Setting**

You can set either supervisor or user password, or both of them. The differences between are:

**Set Supervisor Password:** can enter and change the options of the setup menus.

**Set User Password:** just can only enter but do not have the right to change the options of the setup menus. When you select this function, the following message will appear at the center of the screen to assist you in creating a password.

#### ENTER PASSWORD:

Type the password, up to eight characters in length, and press <Enter>. The password typed now will clear any previously entered password from CMOS memory. You will be asked to confirm the password. Type the password again and press <Enter>. You may also press <Esc> to abort the selection and not enter a password.

To disable a password, just press <Enter> when you are prompted to enter the password. A message will confirm the password will be disabled. Once the password is disabled, the system will boot and you can enter Setup freely.

#### PASSWORD DISABLED.

When a password has been enabled, you will be prompted to enter it every time you try to enter Setup. This prevents an unauthorized person from changing any part of your system configuration.

Additionally, when a password is enabled, you can also require the BIOS to request a password every time your system is rebooted. This would prevent unauthorized use of your computer.

You determine when the password is required within the BIOS Features Setup Menu and its Security option (see Section 3). If the Security option is set to "System", the password will be required both at boot and at entry to Setup. If set to "Setup", prompting only occurs when trying to enter Setup.

### 3.15 Exit Selecting

#### Save & Exit Setup

Pressing <Enter> on this item asks for confirmation:

**Save to CMOS and EXIT (Y/N)?** **Y**

Pressing "Y" stores the selections made in the menus in CMOS— a special section of memory that stays on after you turn your system off. The next time you boot your computer, the BIOS configures your system according to the Setup selections stored in CMOS. After saving the values the system is restarted again.

**Exit Without Saving**

Pressing <Enter> on this item asks for confirmation:

**Quit without saving (Y/N)? Y**

This allows you to exit Setup without storing in CMOS any change. The previous selections remain in effect. This exits the Setup utility and restarts your computer.

**SECTION 4 BIOS SETUP FOR NAGASAKI PANEL PC**

**4.1 BIOS Setting for Nagasaki Panel PCs**

Model No.	Size	Resolution	Mainboard	Main → Advanced Chipset → Select display device	
				Display device	Panel Type
PPC-712	7"	640 x 480	NASA-6822	No matter	CRT
PPC-812	8"	640x480	NASA-6822	CRT+LCD	00
PPC-872	8"	640 x 480	NASA-6822	CRT+LCD	00
PPC-1072-VGA	10.4"	640 x480	NASA-6822	CRT+LCD	00
PPC-1072-SVGA	10.4"	800 x 600	NASA-6822	CRT+LCD	01
PPC-1272	12.1"	800 x 600	NASA-6822	CRT+LCD	01
PPC-1273	12.1"	800 x 600	NASA-6822	CRT+LCD	01
PPC-1511	15"	1024 x 768	NASA-6822	CRT+LCD	0A
PPC-1513	15"	1024 x 768	NASA-6822	CRT+LCD	0A
PPC-1514	15"	1024 x 768	NASA-P411	CRT+LCD	8
PPC-1572	15"	1024 x 768	NASA-6822	CRT+LCD	0A
PPC-1573	15"	1024 x 768	NASA-6822	CRT+LCD	0A
PPC-1574	15"	1024 x 768	NASA-P411	CRT+LCD	8
PPC-1575	15"	1024 x 768	NASA-6822	CRT+LCD	0A
PPC-1576	15"	1024 x 768	NASA-P411	CRT+LCD	0A
PPC-1577	15"	1024 x 768	NASA-6822	CRT+LCD	0A
PPC-1772	17"	1280 x 1024	NASA-6822	CRT+LCD	0D
PPC-1773	17"	1280 x 1024	NASA-6822	CRT+LCD	0D
PPC-1774	17"	1280 x 769	NASA-6822	CRT+LCD	0C
PPC-1912	19"	1280 x 1024	NASA-6822	CRT+LCD	0D
PPC-2172	21"		NASA-6822	CRT	